

\* OPTIONALLY SUPPLIED

ITEM	QTY	NAME	DRAWING NO.	GRADE	SHAPE	UNIT WT.	SIZE	VENDOR	WEIGHT
1	2	PNEUMATIC LIFT DECK	D-75490 (LH), D-75490-1 (RH)	SS 304		211.40			422.8
2	1	DECK FRAME	D-75489	SS 304		636.00			636.0
3	1	SPACER BAR	B-75495-2	SS 304		12.80			12.8
4	1	SAFETY BAR	B-74174-2	SS 304		9.30			9.3
5	1	MOUNTING BRACKET	A-34544	SS 304					
6	4	LOAD CELL	B-36508	SS 304		18.50	136-10CH		40.9
7	4	CYLINDER CLEVIS WELDMENT	A-35594	SS 304					
8	16	HHCS		SS 304			M10X1.5X20mm (0.75) PART OF ITEM 9		
9	4	PNEUMATIC LIFT CYLINDER	B-73734	SS 304		7.70	2.50Ø X 5.00 STROKE	SMC CORP.	30.8
10	8	QUICK RELEASE PIN	A-73067-4	SS 18-8					
11	4	VENT	BV-1	CS/NPL			0.125 NPT	UNIVERSAL COMPONENTS, INC.	
12	3	MALE RUN TEE	SS-200-3 TMT	SS 316				SWAGelok	
14	1	MALE CONNECTOR	SS-200-1-2	SS 316				SWAGelok	
15	1	MALE CONNECTOR	SS-200-1-4	SS 316				SWAGelok	
16	1	BALL VALVE 3-WAY	B43XF4	BRASS				WHITEY	
17	12	CLAMP	A-34653-1	SS 304					
18	12	HHCS		SS 18-8			0.375-16UNC X 1.00		
19	12	WASHER	A-73699-3	SS 304					
20	8	SHIM	A-75496	SS 304					
21	1	CAUTION SIGN	A-34550	ALUM					
22	0	*PIT ARRANGEMENT	D-75488				0.38 DECK (M18X1.5)		
23	4	CLEVIS	A-34541-2	SS 303					

- GAGE LOAD CELLS WITH SCALE INSTALLED
- REMOVE NYLON SCREW
- FILL LOAD CELL WITH FLUID TO A GAGING OF:  
0.025 - 0.030  
(GAP CLOSSES WHEN FILLING WITH FLUID)

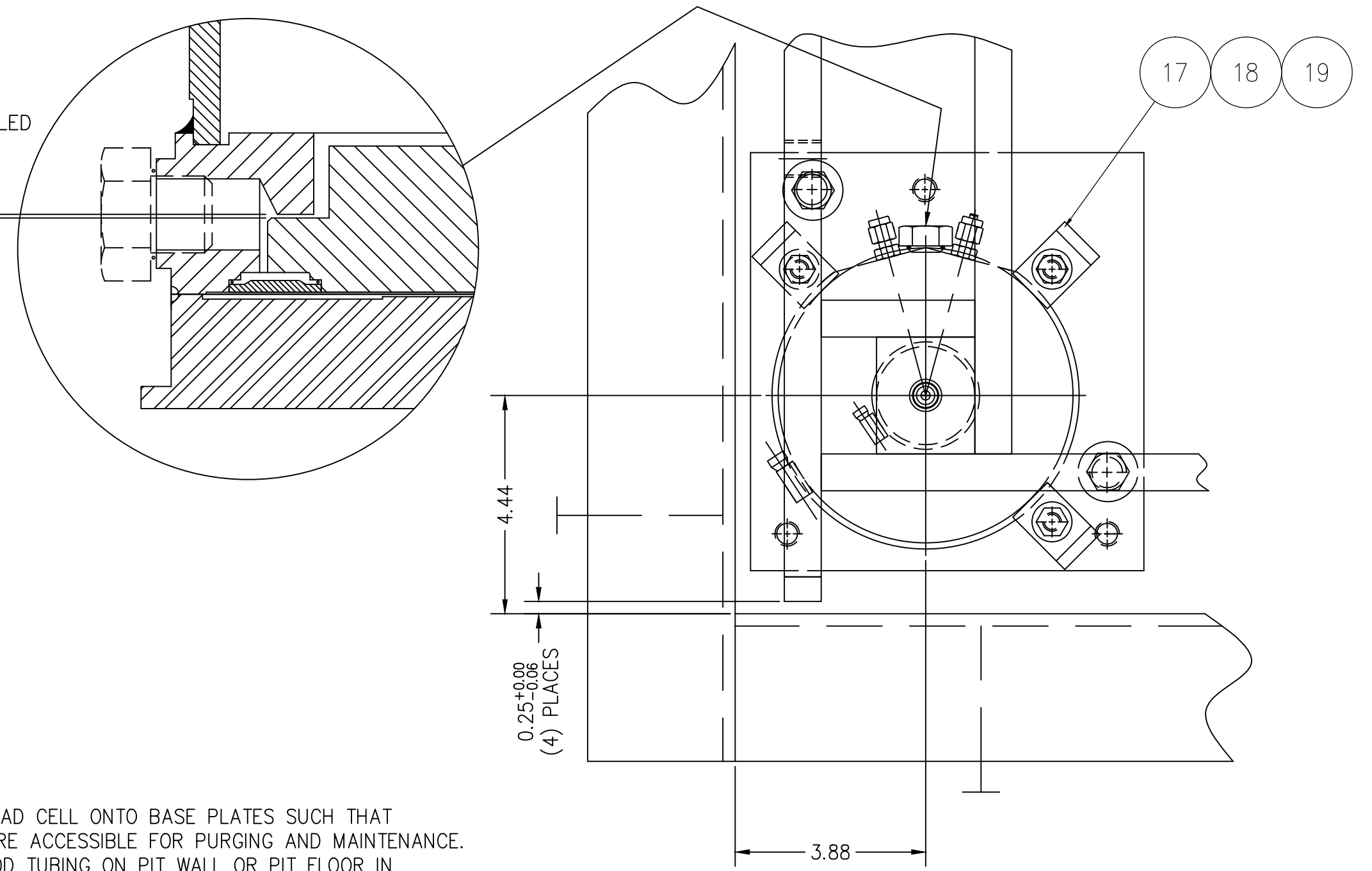

- NOTES:
- INSTALL LOAD CELL ONTO BASE PLATES SUCH THAT FITTINGS ARE ACCESSIBLE FOR PURGING AND MAINTENANCE.
  - RUN 1/8 OD TUBING ON PIT WALL OR PIT FLOOR IN 1/2 INCH CONDUIT.
  - PLACE SCALE AND CHECK FOR EVEN GAP ALL AROUND.
  - IF GAP IS NOT EVEN, LOOSEN CLAMPS AND RELOCATE LOAD CELL.

PRELIMINARY NOT FOR CONSTRUCTION. FOR ILLUSTRATION ONLY.

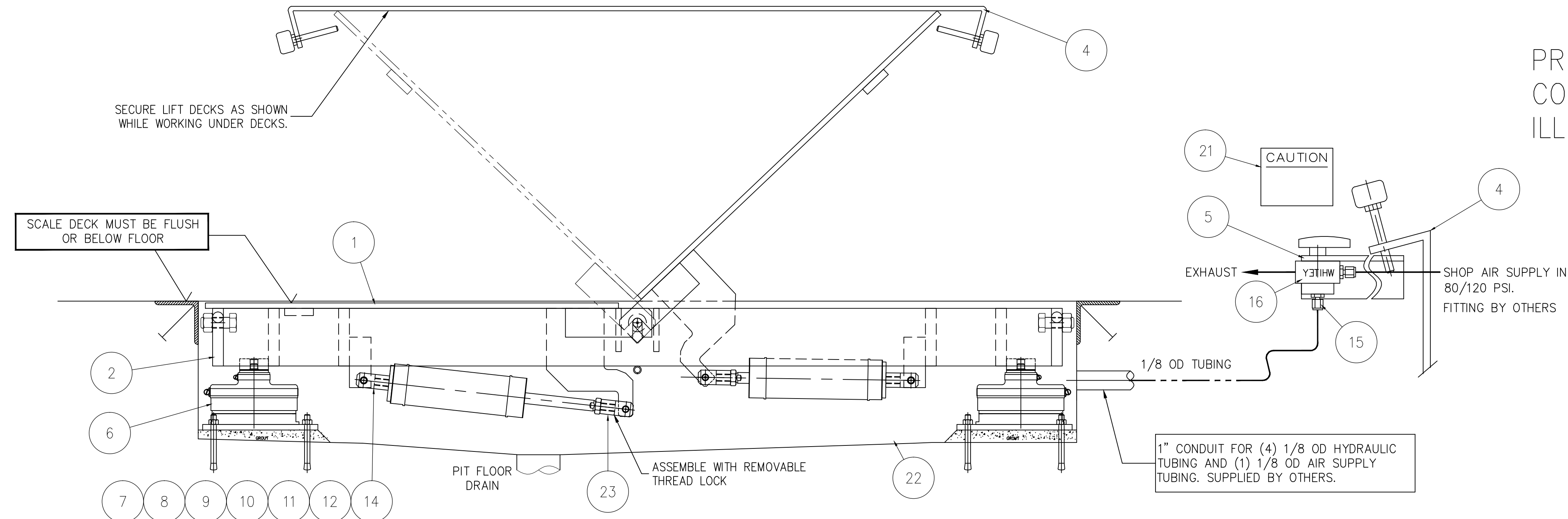
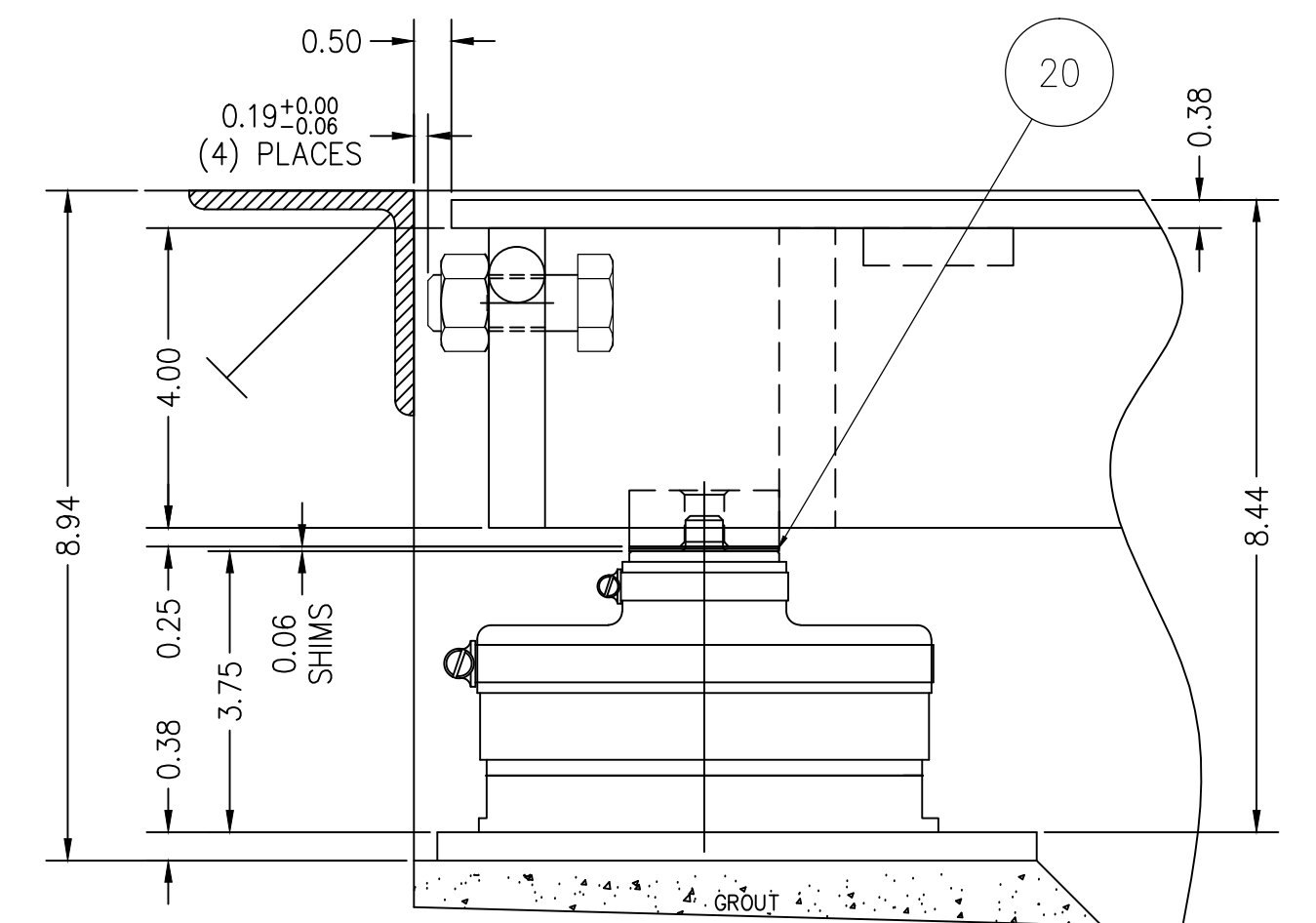

C	ITEMS 15 & 16 BALLOONS SEPARATED IN DETAIL	04/21	CEM	ALL SHARP CORNERS AND EDGES TO BE BROKEN	EMERY WINSLOW SCALE COMPANY SEYMOUR, CT U.S.A TERRE HAUTE, IN.
B	ITEM 13 OMITTED	12/20	CEM	UNLESS OTHERWISE SPECIFIED DIMENSIONS ARE IN INCHES	
A	ITEMS 1 & 2 UPDATED	10/20	CEM	MACHINING FABRICATION XX ± .01 ± .13 XXX ± .005	SCALE ASSEMBLY 710S-55-20K-AIR-NT (10K AXLE CAPACITY)
LTR	REVISION	DATE	BY	DRAWN CEM DATE 07/13/2020	SCALE 1:5 FIRST USED ON DRAWING NO. D-75487 REV. C
THIS DRAWING IS THE PROPERTY OF EMERY WINSLOW SCALE COMPANY SEYMOUR, CONNECTICUT. THE INFORMATION CONTAINED HEREIN IS CONFIDENTIAL AND IS NOT TO BE USED OR DISSEMINATED TO OTHERS WITHOUT THE EXPRESS WRITTEN CONSENT OF EMERY WINSLOW SCALE COMPANY.					