

DASH NO.	LOAD CELL MODEL NO.	SCALE MODEL NO.	DEAD WEIGHT	CAPACITY
D-36280-1	102S-5.0-M2 B-34321	709-46-5	445	2,000/5,000 lb 4,000 lb AXLE LOAD
D-36280-2	102S-10.0-M2 B-34321-1	709-46-10	445	10,000 lb 8,000 lb AXLE LOAD

ITEM NO.	DESCRIPTION	QTY	MATERIAL	UNIT WT.	PART NO.	SIZE	WT.
1	DECK FRAME	1	SS 304		D-36282-1		183
1	DECK FRAME	1	SS 304		D-36282-2		248
2	LIFT DECK SET	1	SS 304		D-36283	DECK PLATE AS PER FACTORY ORDER	262
3	BASE FRAME	1	SS 304		D-36281		101
4	LOAD CELL	4	SS 304		SEE TABLE		
5	ROD CLEVIS	8	SS 304		A-73497-2	M10 X 1.5	
6	ROD CLEVIS	8	SS 304		A-34541	0.500-20 UNF	
7	STAYBAR	2	SS 304		A-35900-1	(0.500-20 UNF X 8.75)	
8	CLEVIS PIN	8	SS 18-8		A-73067-1-B		
9	COTTER PIN	8	SS 18-8		A-73068-3-A		
10	SPACER BAR	1	SS 304		B-36498-3		
11	VERTICAL STOP THRD ROD	4	SS 304			0.500-20 UNF X 4.00	
12	VS HEX NUT WELDMENT	8	SS 304		A-35703		
13	HEX NUT, HALF	16	SS 304			0.500-20 UNF	
14	QUICK RELEASE PIN	8	SS 18-8		A-73067-3-B		
15	UNION	4	SS 316		SS-200-6	SWAGelok OR EQUAL	
16	SHIM	4	SS 304		A-73305		
17	HHCS	8	SS 304			0.250-20 UNC X 0.50	
18	FHSCS	8	SS 304			0.250-20 UNC X 0.50	
19	LASH	4	SS 304		A-35557		
20	GAS SPRING FOR 0.25 DECK	4	SS 316		A-73066-2-A		
20	GAS SPRING FOR 0.38 DECK	4	SS 316		A-73066-4-A		
21	EYE BOLT	2	CS		A-73698-5	(0.625-11 X 1.75)	
22	PIT ARRANGEMENT 0.25	1	SS 304		D-33347		
22	PIT ARRANGEMENT 0.38	1	SS 304		D-33347-2		
23	STAYBAR	2	SS 304		A-35900-4	(0.500-20 UNF X 15.25)	

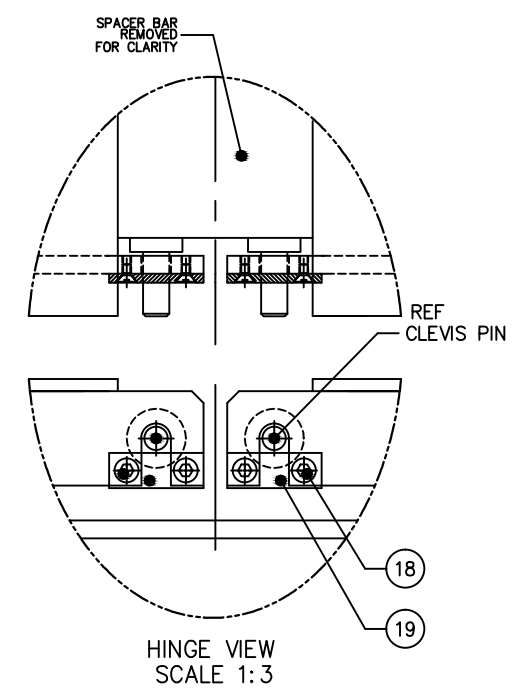
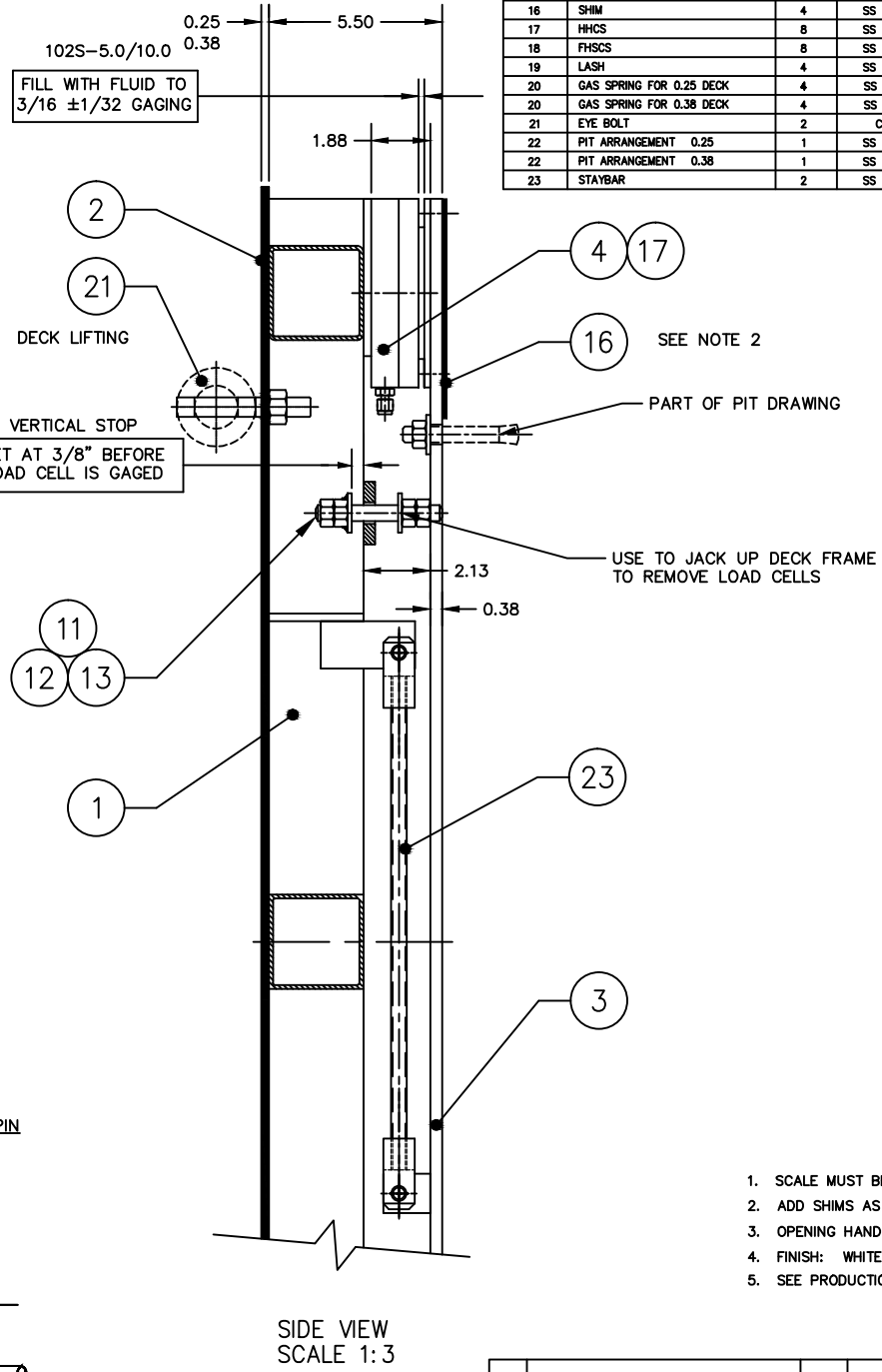
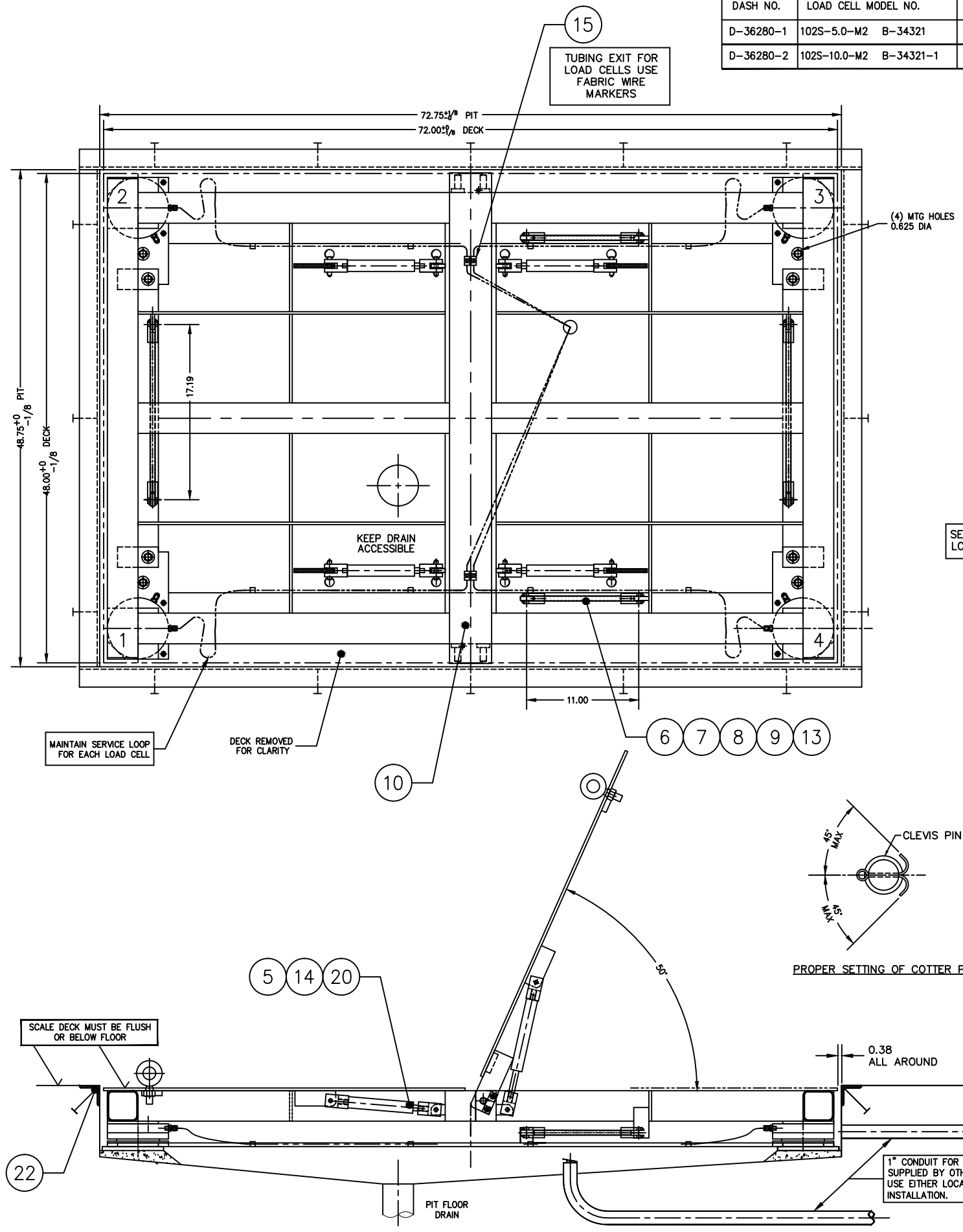

- SCALE MUST BE PLACED INTO PIT WITH DECK SET ASSEMBLED.
 - ADD SHIMS AS REQUIRED UNDER SCALE BASE FRAME & TACK WELD.
 - OPENING HAND FORCE 45 lb.
 - FINISH: WHITE SAND BLAST TO (125 MIC).
 - SEE PRODUCTION CONTROL DRAWING D-35654.
- PRELIMINARY NOT FOR CONSTRUCTION. FOR ILLUSTRATION ONLY.

DEBURR ALL CORNERS AND EDGES		EMERY WINSLOW SCALE COMPANY SEYMOUR, CT U.S.A TERRE HAUTE, IN.	
C	-1 L/C CALL OUT WAS B-34328-2 (102S-3.0-M1)	06/14	CEM
B	BOM & CLEVIS UPDATED, COTTER PIN DETAIL ADDED	11/12	CEM
A	CENTER TUBING AND CLEVIS PINS ADDED	08/09	TMC
REV	DESCRIPTION	DATE	BY
THIS DRAWING IS THE PROPERTY OF EMERY WINSLOW SCALE COMPANY. SEYMOUR, CONNECTICUT. THE INFORMATION CONTAINED HEREIN IS CONFIDENTIAL AND IS NOT TO BE USED OR DISSEMINATED TO OTHERS WITHOUT THE EXPRESS WRITTEN CONSENT OF EMERY WINSLOW SCALE COMPANY.		DRAWN:CBM/OT DATE: 6/29/06	
CHECKED: DATE:		ACAD FILENAME: AC01418	
LAYERS USED: ALL		SCALE FIRST USED ON DRAWING NO. REV 1:6 D-36280 C	