

STEP 1: SLIDE THE REMOVABLE PINS DOWN OVER THE DOWEL PINS ON THE BASE PLATE. THE REMOVABLE PINS MUST SLIDE FREELY OVER THE DOWELS. SLOWLY AND CAREFULLY LOWER THE PLATFORM DOWN INTO THE PIT. KEEP THE PLATFORM LEVEL. THE REMOVABLE PINS MUST ALL PASS THROUGH THE CENTER HOLES IN THE CAPTURE BLOCKS.

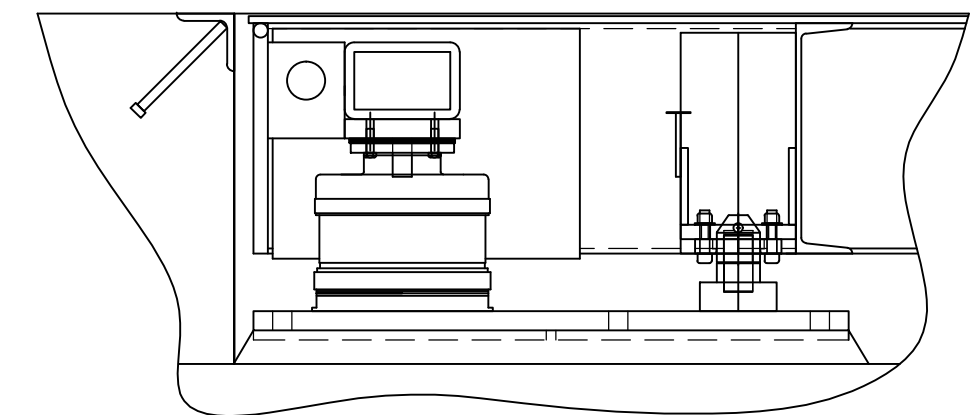

STEP 2: LOWER THE PLATFORM ALL THE WAY DOWN ONTO THE LOAD CELL. VISUALLY CONFIRM THAT THE LOAD CELL HEAD IS SEATED SQUARELY IN THE CENTERING RING.

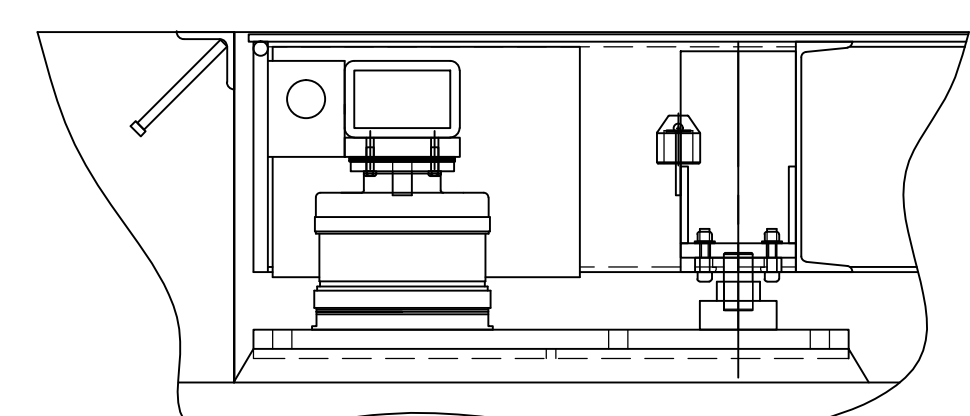

STEP 3: PULL THE REMOVABLE PIN UP THROUGH THE CAPTURE BLOCK AND STORE IT ON THE POST PROVIDED. THE SCALE IS READY FOR RECALIBRATION (AT THE DIGITAL INDICATOR).

DECK RE-POSITIONING PROCEDURE (AFTER INITIAL INSTALLATION)  
SCALE 1:10

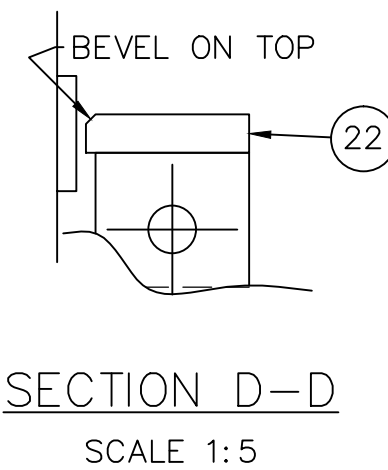

SECTION D-D  
SCALE 1:5

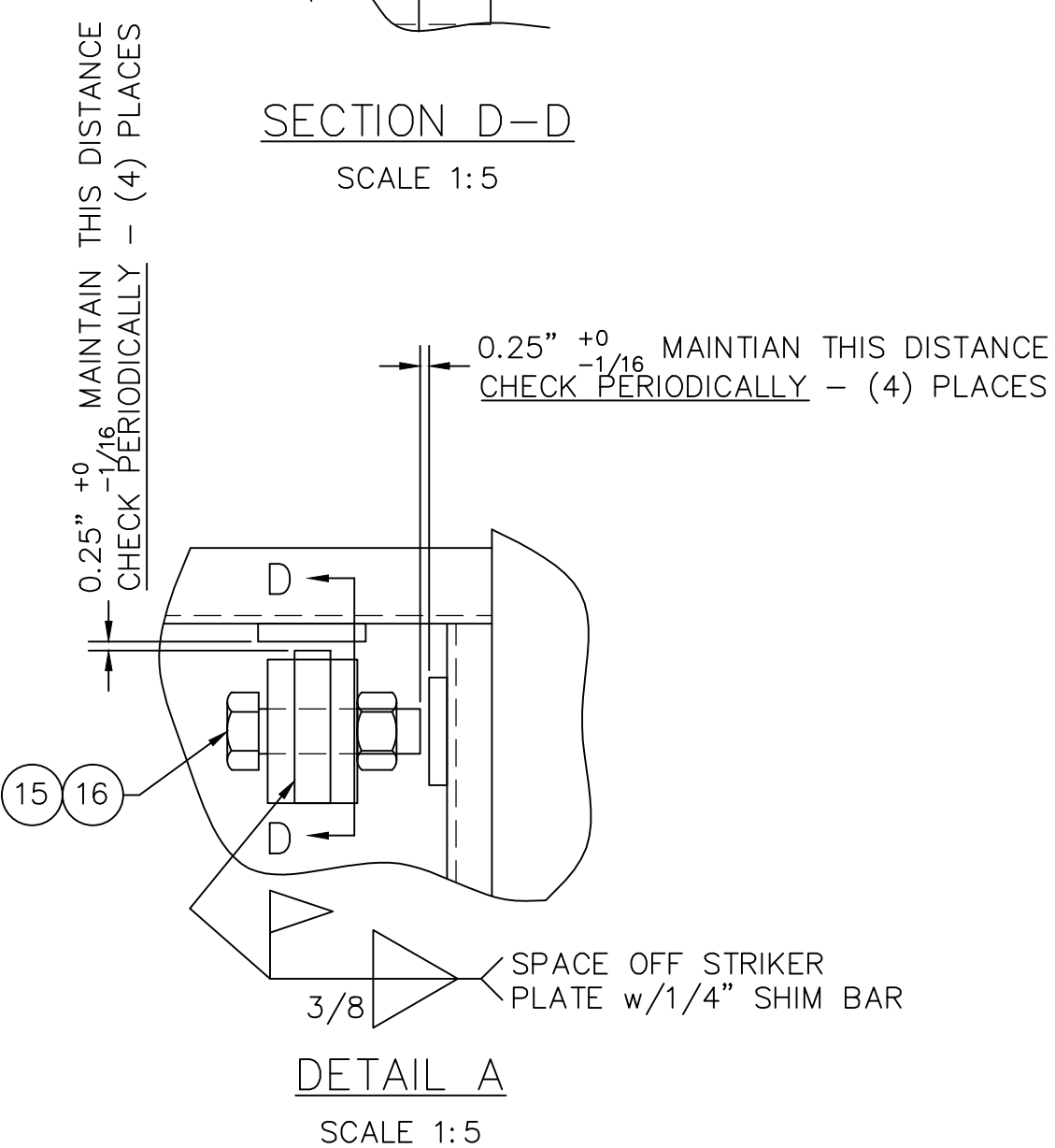

DETAIL A  
SCALE 1:5

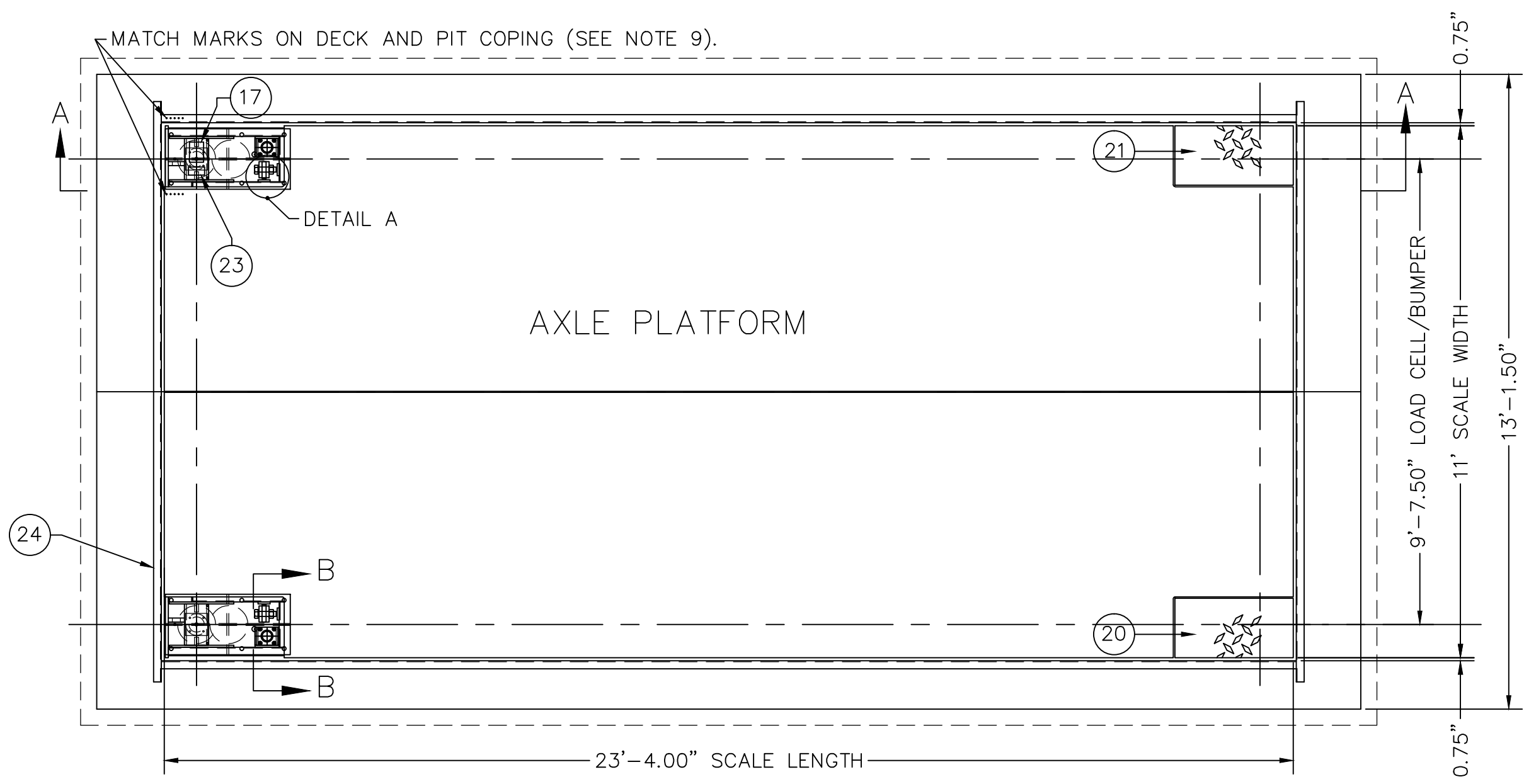

AXLE PLATFORM

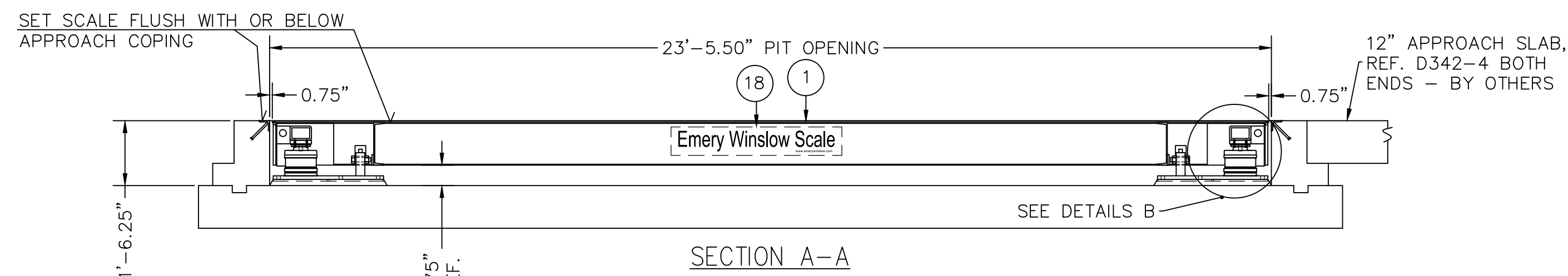

SECTION A-A

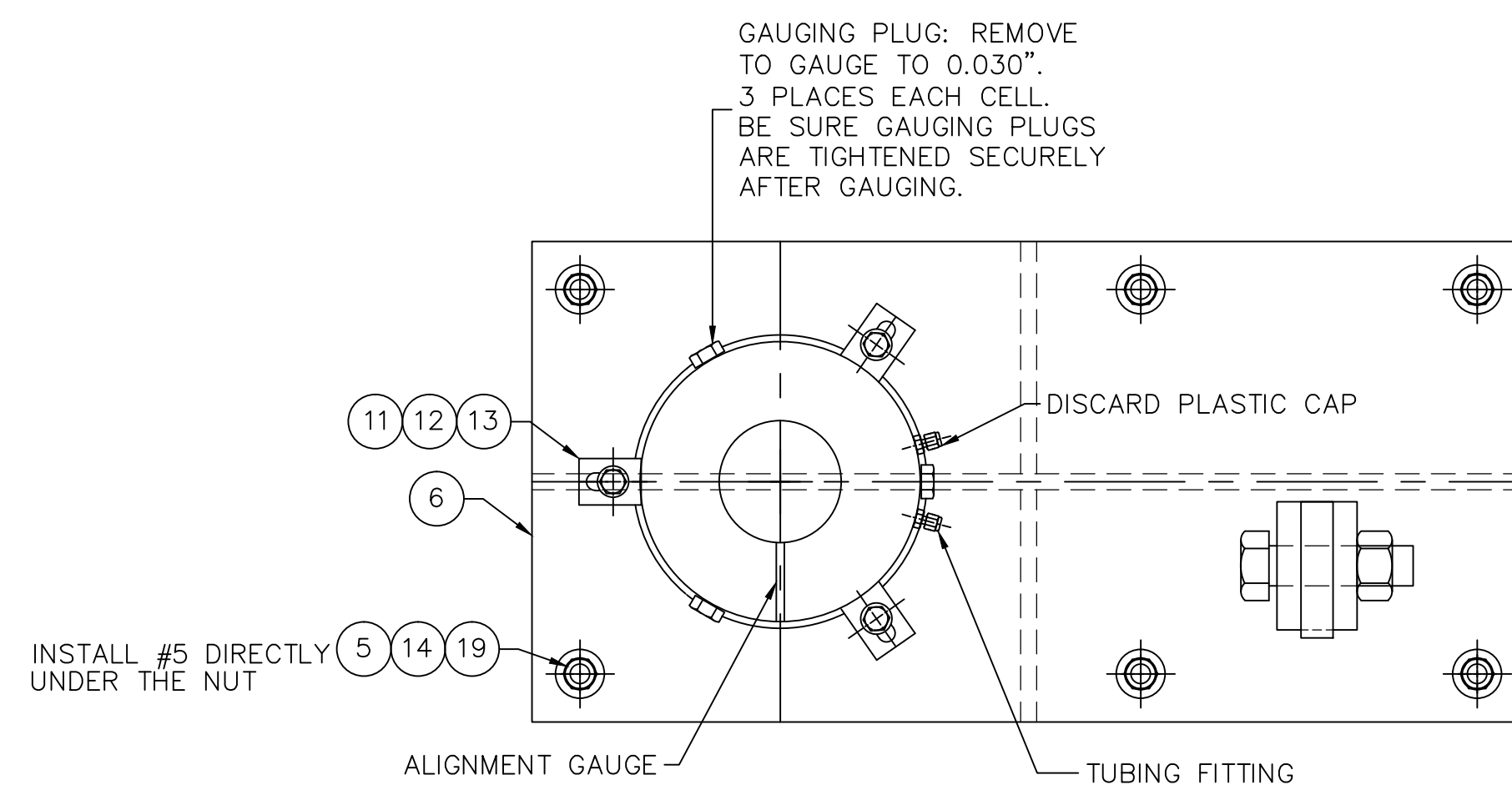

TYPICAL TOP VIEW OF CELL ON BASE PLATE  
SCALE 1:5

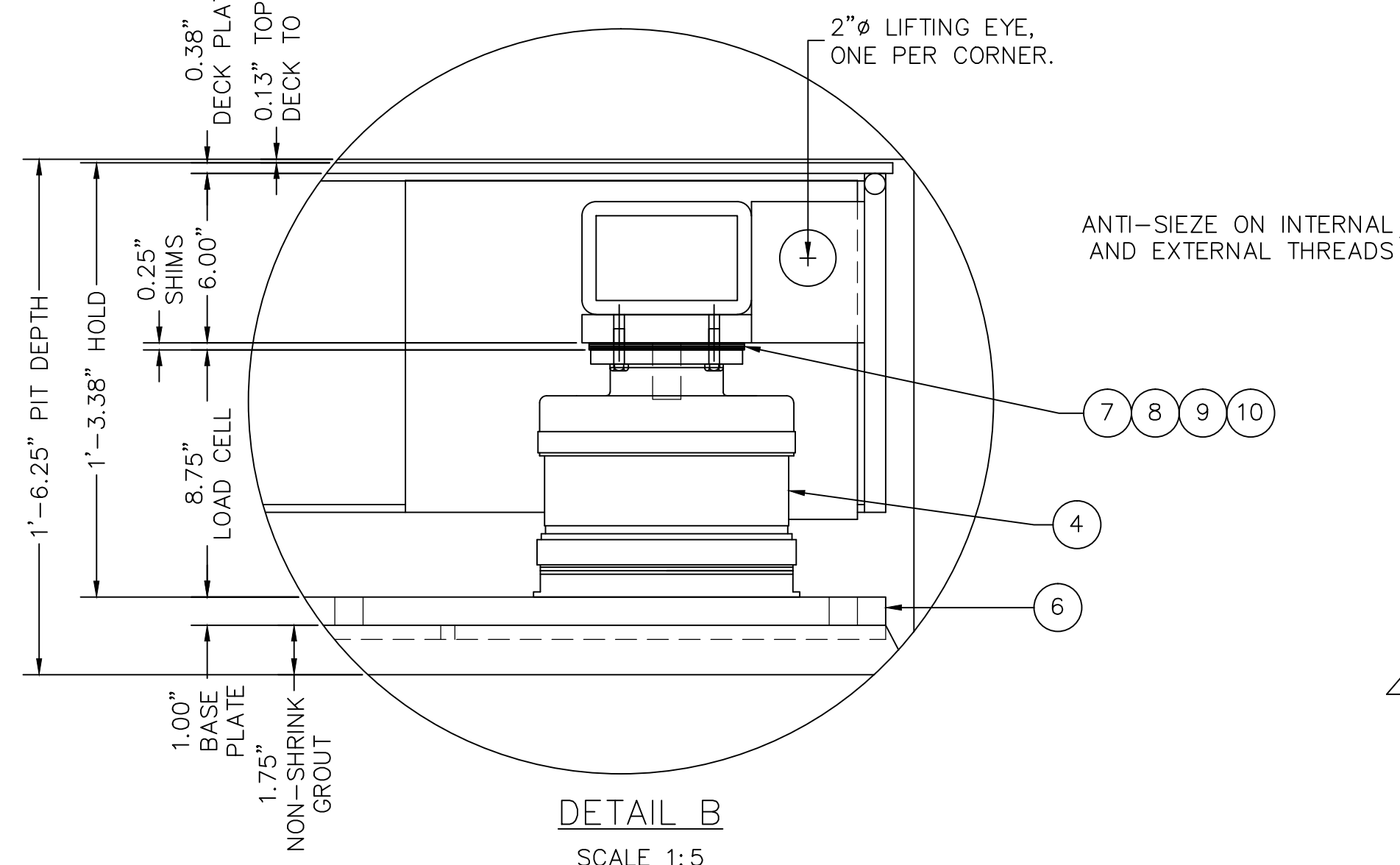

DETAIL B  
SCALE 1:5

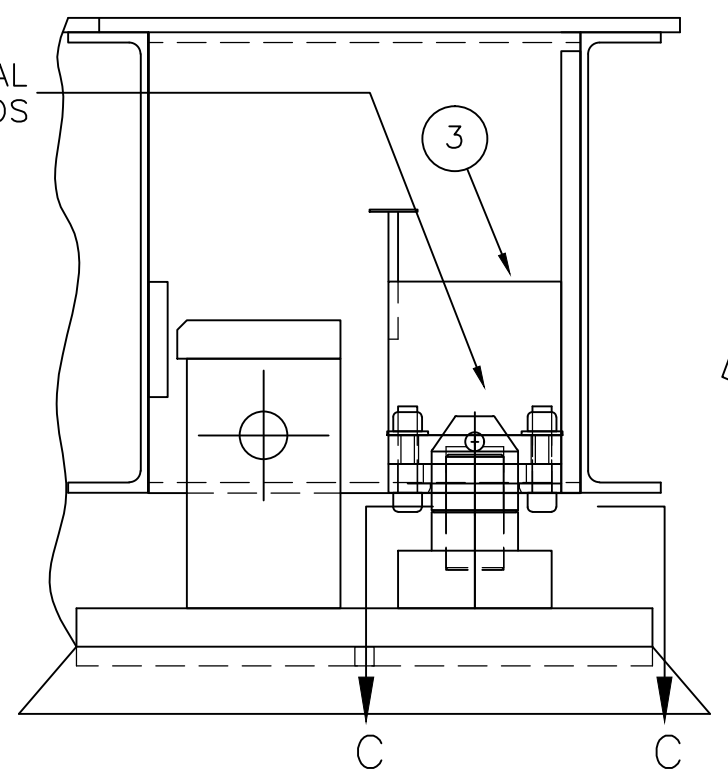

SECTION B-B  
ROTATED 90°; SCALE 1:5

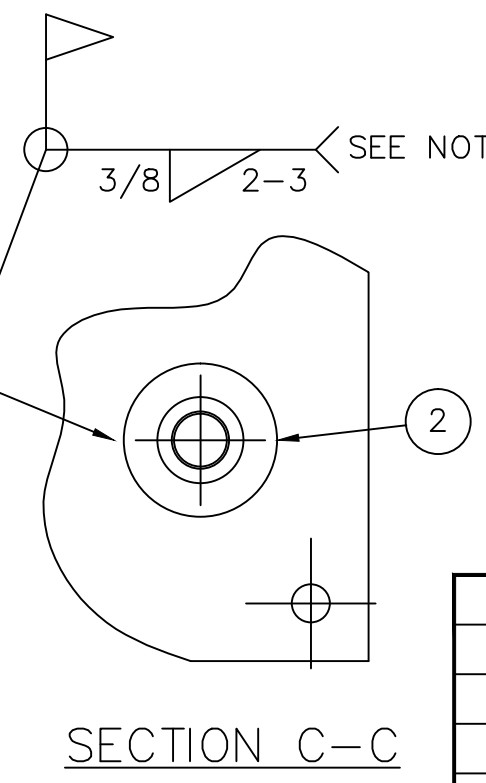

SECTION C-C  
SCALE 1:5

ITEM NO.	DESCRIPTION	QTY	MATERIAL	UNIT WT.	PART NO.	SIZE	WT.
1	AXLE PLATFORM	1	SEE ASS'Y	10193	D-75029		10193
2	ALIGNMENT PIN ASS'Y	4	SEE ASS'Y	15.50	B-72887-B		62
3	CAPTURE BLOCK ASS'Y	4	SEE ASS'Y	-	B-72888-G		-
4	LOAD CELL	4	SEE ASS'Y	63.00	D-29547-2	136-75-CH; NTEP NP. 88-239-P	252
5	LOCK WASHER	24	SS	-		FOR 0.75Ø	-
6	BASE PLATE	4	ASTM A36	154.00	B-72875-B,-1-B, L.H. AND R.H. PLATES REQUIRED		616
7	CENTERING RING	4	A/R	1.50	B-72884-B		6
8	SHIM	12	SS	0.50	A-29869-1-E	0.06 THICK	6
9	SHIM	8	SS	0.30	A-29869-2-E	0.03 THICK	3
10	HHCS	16	SS	-		0.375-13UNC X 1.25	-
11	CLAMP	12	CS, ZN PL	-	A-29870-2-B		-
12	HHCS	12	SS	-		0.50-13UNC X 1.25	-
13	MS FLAT WASHER	12	SS	-		FOR 0.500Ø, ONE PER CLAMP	-
14	CHEM-STUD W/NUT & WASHER	24	CS ZN PL	-	B-72877-B	0.75 X 12.00	-
15	HHCS	4	GR. 8	-		1.25-7UNC X 4.50 FULL THREAD, ZN PL	-
16	TRI-LOCK NUT	4	GR. 2H	-		1.25-7UNC, ZN PL	-
17	SERIAL NUMBER PLATE	1	SS	-	B-34821-E		-
18	EWSCO DECAL	2	-	-	A-70894-A	8.00 X 48.00	-
19	CHEM-STUD CAPSULE	24	-	-	256702 HILTI OR EQ. HVU 0.75 X 6.63		-
20	COVER RIGHT	2	ASTM A36	72.00	B-73364-1-A (MATCH MARKED TO HATCH)		144
21	COVER LEFT	2	ASTM A36	72.00	B-73364-A (MATCH MARKED TO HATCH)		144
22	TRANSVERSE BUMPER	4	ASTM A36		A-72883 (1.00 X 1.00 X 4.00)		
23	PATENT NO. TAG	1	SS	-	A-74289-B		-
24	APPROACH COPING	2	SEE ASSY	91.00	B-36115-A		182

SEE NOTE 1 ON INSTALLATION  
DRAWING # D-36118 (FOR REFERENCE)

INSTALLATION NOTES:

1. REVIEW THIS DRAWING AS WELL AS D-75028 AND D-36118 BEFORE STARTING ANY WORK.
2. INSTALL THE SCALE AS PER D-36118, EXCEPT THAT CHECKING IS ON THE BASE PLATES.
3. ONCE SCALE HAS BEEN SQUARED AND CENTERED IN THE PIT, ALIGN THE LOAD CELLS USING THE ALIGNMENT GAGE.
4. SET THE LONGITUDINAL CHECK BOLT BUMPERS AS PER DETAIL A.
5. SET THE TRANSVERSE BUMPER BLOCKS AS PER DETAIL A. MAKE SURE THE BEVEL IS ON TOP.
6. POSITION THE PIN ASSEMBLIES UNDER THE CAPTURE BLOCKS AS PER SECTION B-B. CENTER THE REMOVABLE ALIGNMENT PINS IN THE CAPTURE BLOCK HOLES. YOU SHOULD BE ABLE TO PASS A 22 GAGE WIRE THROUGH THE GAPS EVERYWHERE. THE REMOVABLE ALIGNMENT PINS CAN GO DOWN THROUGH THE CAPTURE BLOCKS AND ONTO THE DOWEL PINS.
7. WELD THE PIN ASSEMBLY BASES TO THE BASE PLATES AS PER SECTION C-C. IT MAY BE NECESSARY TO REMOVE THE PLATFORM FOR WELDING. SOLIDLY TACK WELD THE ALIGNMENT PIN ASSEMBLIES TO THE BASE PLATES AND PULL THE REMOVABLE PINS BEFORE REMOVING THE PLATFORM. USE ER308LSi WELDING ROD OR CONSULT LOCAL WELDING SUPPLY VENDOR, 304SS WELDED TO A36 CS.
8. REPLACE THE PLATFORMS AFTER WELDING AND REMOVE THE ALIGNMENT PINS AND STORE THEM ON THE POSTS PROVIDED. SEE DECK RE-POSITIONING PROCEDURE.
9. MATCH MARK ONE CORNER OF THE SCALE WITH ONE CORNER OF THE PIT. THE PLATFORM MUST GO BACK IN THE PIT THE SAME WAY EACH TIME.

MISCELLANEOUS NOTES:

1. FOLLOW THE DECK RE-POSITIONING PROCEDURE WHEN SETTING THE PLATFORM BACK INTO THE PIT. FAILURE TO DO SO COULD RESULT IN THE LOSS OF THE ABILITY TO READILY RE-LOCATE THE PLATFORM ONCE REMOVED FROM THE PIT. DO NOT TRY TO FORCE THE REMOVABLE ALIGNMENT PIN ONTO THE DOWEL PIN. WIPE THEM BOTH CLEAN AND LIGHTLY GREASE THE ENGAGEMENT SURFACES BEFORE USE.
2. KEEP THE THE CAPTURE BLOCK GREASED. CHECK FOR DEBRIS INSIDE THE BLOCK.
3. KEEP THE DOWEL PIN AND REMOVABLE ALIGNMENT PIN CLEAN AND LIGHTLY GREASED.

PRELIMINARY NOT FOR  
CONSTRUCTION. FOR  
ILLUSTRATION ONLY.  
USE FIVE STAR GROUT OR EQUAL

FOR NON COMMERCIAL SCALES PROVIDE AN APPROACH OF 2 FEET MINIMUM LENGTH WHICH IS LEVEL AND IN SAME PLANE AS THE PLATFORM.

FOR COMMERCIAL SCALES CHECK WITH LOCAL WEIGHTS AND MEASURES OFFICIALS BEFORE STARTING CONSTRUCTIONS.

NATIONAL INSTITUTE OF STANDARDS AND TECHNOLOGY (NIST) HANDBOOK 44 REQUIRES:

- A) A STRAIGHT APPROACH OF AT LEAST ONE-HALF THE LENGTH OF THE PLATFORM.
- B) NOT LESS THAN 10 FEET OF APPROACH ADJACENT TO THE PLATFORM TO BE CONSTRUCTED OF CONCRETE OR SIMILAR DURABLE MATERIAL AND BE LEVEL AND IN THE SAME PLANE AS THE PLATFORM.

DRAWING REFERENCES:

- D-75028 SHALLOW PIT FOUNDATION/ANCHOR BOLT LAYOUT
- D-36118-G INSTALLATION INSTRUCTIONS
- B-33069-2-H 2 SECTION TUBING DIAGRAM
- NTEP NO. 89-185PA3
- CLC = 58,000 LB CLASS III

FULL SIZE PLOT D-24X36

ALL SHARP CORNERS AND EDGES TO BE BROKEN				EMERY WINSLOW SCALE COMPANY SEYMOUR, CT U.S.A. TERRE HAUTE, IN.			
UNLESS OTHERWISE SPECIFIED DIMENSIONS ARE IN INCHES				MACHINING FABRICATION			
XX = ± .01				± .13			
XXX = ± .005				DRAWN CEM DATE 02/15/17			
THIS DRAWING IS THE PROPERTY OF EMERY WINSLOW SCALE COMPANY SEYMOUR, CONNECTICUT. THE INFORMATION CONTAINED HEREIN IS CONFIDENTIAL AND IS NOT TO BE USED OR DISSEMINATED TO OTHERS WITHOUT THE EXPRESS WRITTEN CONSENT OF EMERY WINSLOW SCALE COMPANY.				CHECKED DATE			
ACAD FILENAME: T05165				SCALE 1:30			
LAYERS USED: ALL				FIRST USED ON DRAWING NO. D-75027			
				REV.			