

ITEM NO.	DESCRIPTION	QTY	MATERIAL	UNIT WT.	PART NO.	SIZE	WT.
1	TRANSDUCER ENCLOSURE ASSEMBLY	1	NEMA 4X		B-35570-2		
2	SCALE 437-1818	1	SS 304		D-33386-1		
3	PEDESTAL	1	SS 304		B-34871-5		
4	LEVELING FEET	4	SS 304		A-34073-2	(0.375-16 UNC)	
5	PEDESTAL MOUNTING PLATE	1	SS 304		A-34628-1		
6	SCREW, HEX HD	4	SS 304		0.250-20 UNC X 0.50		
7	NUT, HEX	4	SS 304		0.250-20 UNC		
8	SCREW, PAN HD	4	SS 304		10-24 UNC X 0.50		
9	NUT, HEX	4	SS 304		10-24 UNC		
10	HEX HD NUT	4	SS 304		0.375-16 UNC		
11	LOGO	1	SS 304		A-35636		
12	BACK PLATE	1	SS 304		B-36312-1		
13	DIGITAL WEIGHT INDICATOR	1	SS 304		7400		
14	SCREW, PAN HD	9	SS 304		6-32 UNF X 0.25		
15	CORD CONNECTOR	1	NYLON		3210	HEYCO	

B-36313

REV.

**Preliminary  
Not for Custruction  
For Illustration Only**

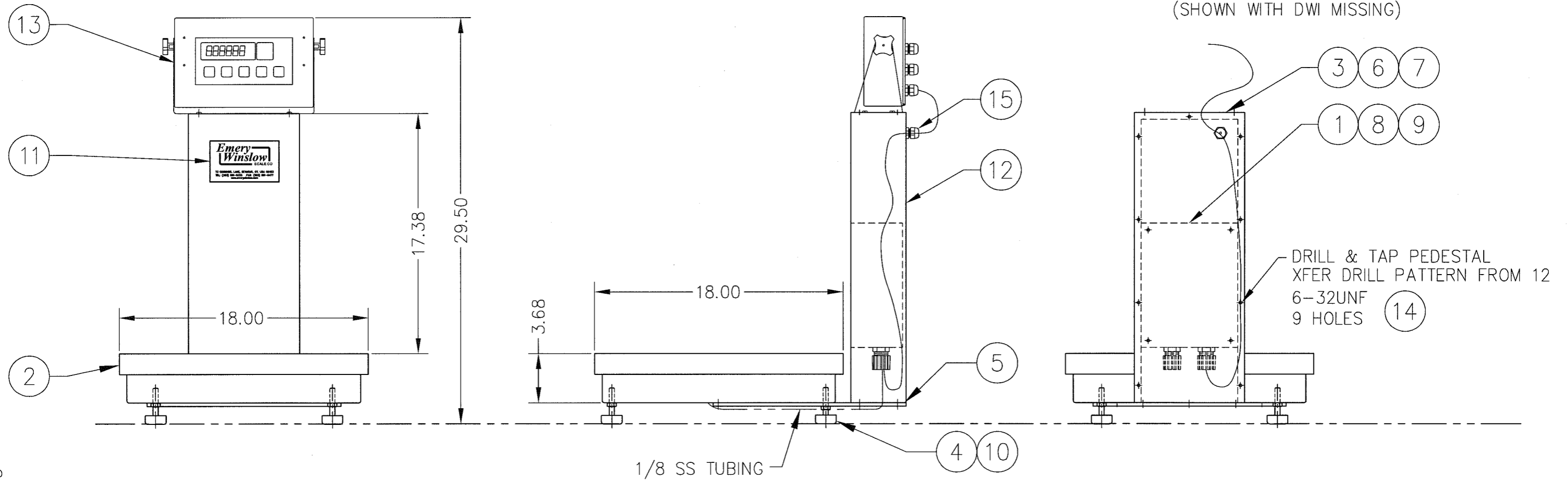

STRAIN GAGE CABLE  
6 WIRE/SHIELDED 26" LG  
(SHOWN WITH DWI MISSING)

DRILL & TAP PEDESTAL  
XFER DRILL PATTERN FROM 12  
6-32UNF  
9 HOLES (14)

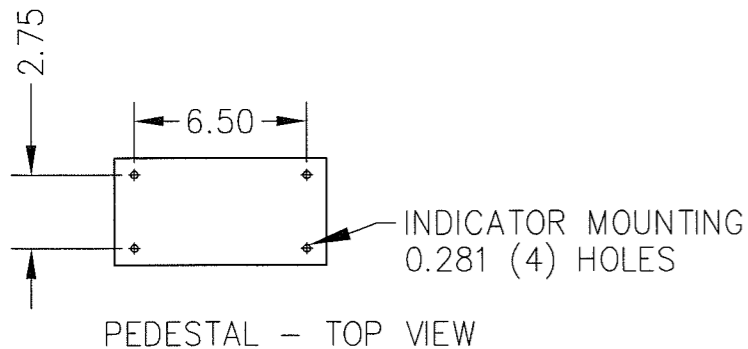

				ALL SHARP CORNERS AND EDGES TO BE BROKEN		EMERY WINSLOW SCALE COMPANY	
				UNLESS OTHERWISE SPECIFIED DIMENSIONS ARE IN INCHES		SEYMOUR, CT. U.S.A. TERRE HAUTE, IN.	
				DECIMALS FRACTIONS ANGLES		437 BENCH SCALE - 21" PEDESTAL	
				.XX = ± .010 ± ±		18 X 18 WEIGHSQUARE	
				.XXX = ± .005 ± ±		175-M1 PRESSURE TRANSDUCER	
LTR	REVISION	DATE	BY	DRAWN	DATE	7400 DIGITAL WEIGHT INDICATOR	
				CHECKED	DATE	200 LB CAPACITY	
THIS DRAWING IS THE PROPERTY OF EMERY WINSLOW SCALE COMPANY SEYMOUR, CONNECTICUT. THE INFORMATION CONTAINED HEREIN IS <u>CONFIDENTIAL</u> AND IS NOT TO BE USED OR DISSEMINATED TO OTHERS WITHOUT THE EXPRESS WRITTEN CONSENT OF EMERY WINSLOW SCALE COMPANY.				ACAD FILENAME: ACO0324		SCALE	FIRST USED ON
				LAYERS USED: 22, A100-A102		1:8	DRAWING NO.
							B-36313
							REV.