

ITEM NO	DESCRIPTION	QTY	MATERIAL	UNIT WT	PART NO	SIZE	WT
1	TOP FRAME	1	A/R		D-33161		
2	BASE PAN ASSY	1	A/R		D-33160-2		
3	TORQUE TUBE (LONG)	1	A/R		C-28324-2		
4	TORQUE TUBE (SHORT)	1	A/R		C-28323-2		
5	FLEXURE CLAMP	16	SS 304		A-28390-1	CASTING	
6	FLEXURE	8	SS 302		A-28347-3	0.03 THICK	
7	SHIM	A/R	SS 302		A-28115-1 (.004), -2 (.010)		
8	SHIM SPACER	4	SS 302		A-28115-4	0.06 THICK	
9	SPRING PIN	16	STAINLESS STEEL NON-MAGNETIC		0.25 DIA X 0.75		
10	SCREW HEX HD	32	SS 304		0.375-24 UNF X 1.00		
11	SCREW HEX HD	4	SS 304		0.312-18 UNC X 1.50		
12	SCREW HEX HD	2	SS 304		0.250-20 UNC X 0.75		
13	NUT HEX	4	SS 304		0.312-18 UNC		
14	LOAD CELL	1	SS 304		SEE TABLE BELOW		
15	FOOT	4			SEE TABLE BELOW		
16	NUT HEX	4	SS 304		0.375-16 UNC		
17	FILLING VALVE	1	A/R		A-29501	(WHEN REQD)	
18	BULKHEAD UNION	1	SS 316		SS-200-61	SWAGelok (WHEN REQD)	
19	TUBING	A/R	A/R		0.125 OD X 0.03 WALL		
20	NUT, HEX	2	SS 304		0.250-20 UNC		
21	COVER	1	A/R		B-28114-12		
22	HHCS	4	SS 304		0.375-16 UNC X 1.75		
23	FOOT/NONSKID PAD	4	DELIN		0.375-16 UNC X 1.25	MCMaster CARR P/N 6103K17	

DASH NO.	SCALE CALIBRATION (lb)	LOAD CELL	(ITEM 14)	WHEN SPECIFIED FOOT (ITEM 15)
-1	100 X 0.05	102S-0.7 2.00 IN SQ	(B-35292)	A-34073-2
-2	300 X 0.05	102S-0.7 2.00 IN SQ	(B-35292)	A-34073-2
-3	500 X 0.1	102S-2.5 M1 4.33 IN SQ	(B-34326-1)	ITEMS 22, & 23
-4	1000 X 0.2	102S-2.5 M1 4.33 IN SQ	(B-34326-1)	ITEMS 22, & 23

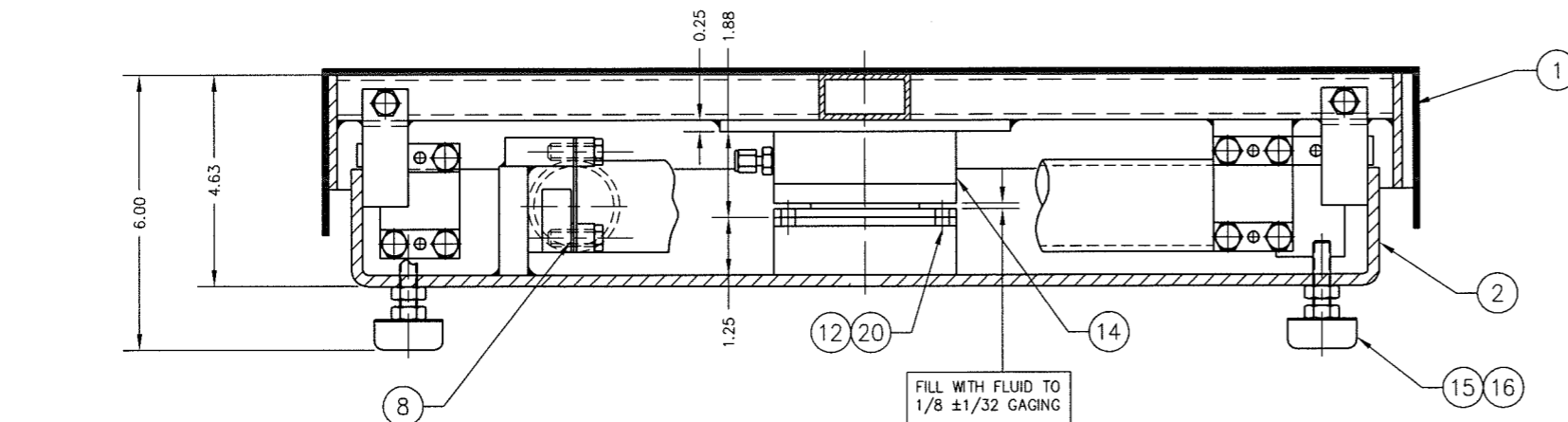

SECTION B-B
SCALE 1:1

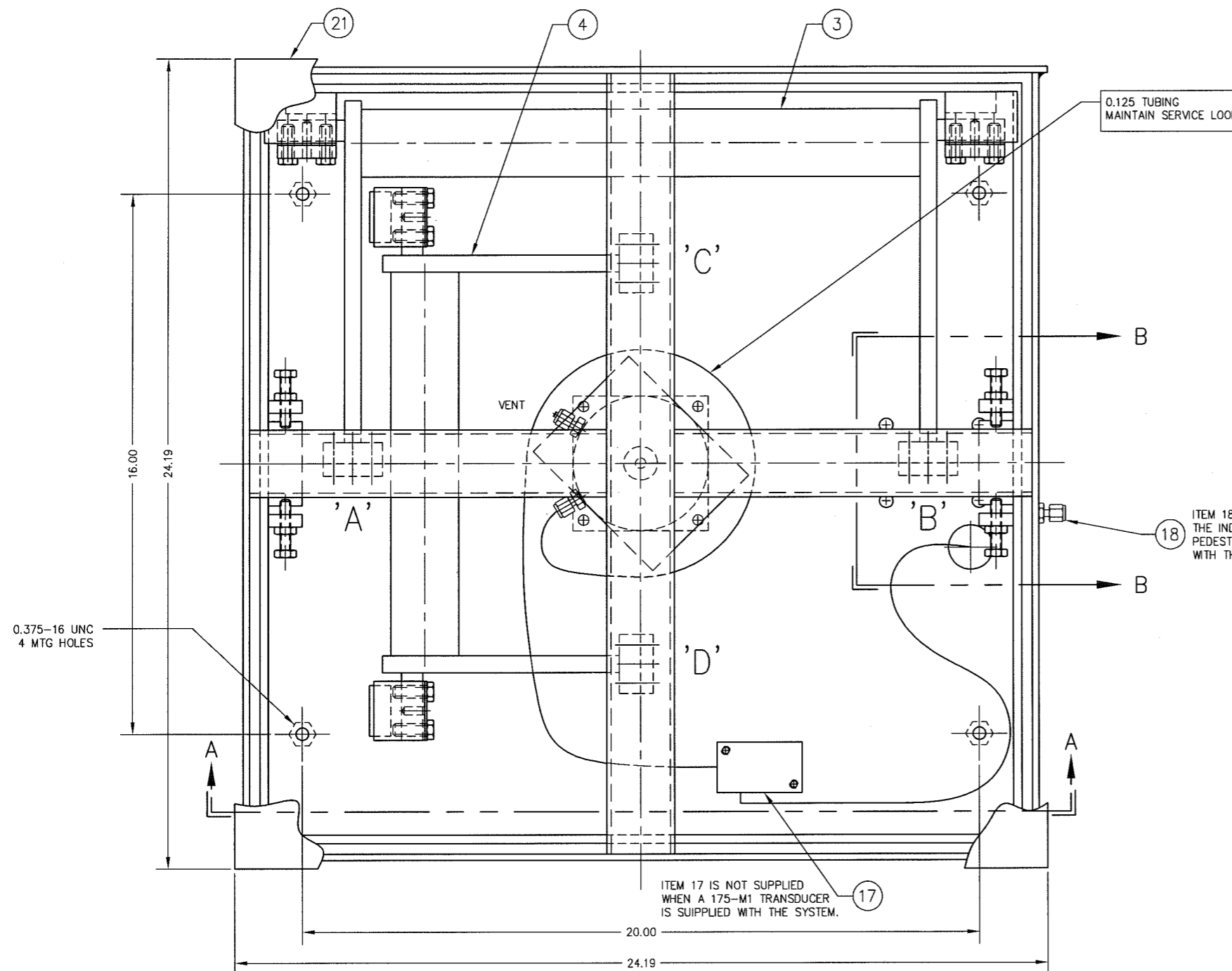
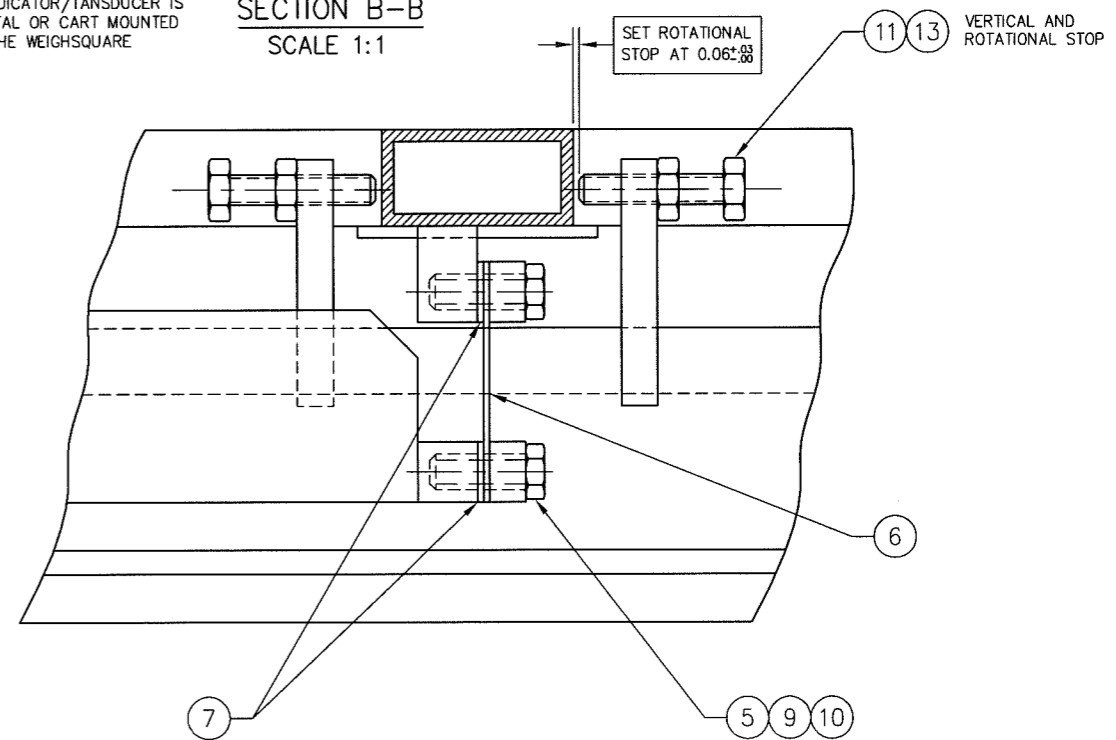

PLACE AT BOTH POSITIONS

MATERIAL:
-Y CARBON STEEL
-Z STAINLESS STEEL 304

FOR CORNER CALIBRATION SHIM ENDS A, B, C, OR D. ADD SHIMS TO THE LOW WEIGHT READING SIDE(S) ONLY. PLACE BETWEEN THE FLEXTURE AND MOUNTING SURFACE.

REV	DESCRIPTION	DATE	BY
H	NOTES FOR ITEM 17, 18 ADDED	1/14/03	JDS
G	CHART INFO UPDATED	4/4/01	CBM
F	500 lb ADDED & FOOT SPECS	2/21/00	CBM
E	100 lb CAPACITY ADDED	1/13/00	CBM
D	CAD REDRAWN, WAS SIZE C	7/2/98	JDS

THIS DRAWING IS THE PROPERTY OF EMERY WINSLOW SCALE COMPANY SEYMOUR, CONNECTICUT. THE INFORMATION CONTAINED HEREIN IS CONFIDENTIAL AND IS NOT TO BE USED OR DISSEMINATED TO OTHERS WITHOUT THE EXPRESS WRITTEN CONSENT OF EMERY WINSLOW SCALE COMPANY.		DRAWN: JDS DATE: 7/2/98	
CHECKED: DATE:		SCALE: 1:2	
ACAD FILENAME: AC00564		FIRST USED ON: DRAWING NO. D-34074-	
LAYERS USED: 1-8		REV H	

EMERY WINSLOW SCALE COMPANY SEYMOUR, CT U.S.A. TERRE HAUTE, IN.	
WEIGHSQUARE ASSEMBLY 737M/S-2424-1000	

FROM AC00488